

# TOSHIBA

## Instruction Manual RO Tabletop Water Purifier

MODEL

**TWP-TSR76TTH(W)**



Please read the manual carefully before operating the water purifier.  
Retain it for future reference.

# DIRECTORY

1. Safety Instruction-----	1
1-1 Safety instructions-----	1
1-2 Packing list-----	5
2. Product Introduction-----	5
2-1 Name of parts-----	5
2-2 Control panel-----	6
2-3 Electric schematic diagram-----	6
2-4 How to use-----	7
2-5 Daily maintenance-----	7
3. Troubleshooting-----	9
4. Filter Introduction-----	9
4-1 Filter introduction-----	10
4-2 Filter change-----	10
5. Technical Parameters-----	10
5-1 Basic parameter-----	12
	12

The packaging material used is recyclable; we recommend that you separate plastic, paper and cardboard and give them to recycling companies. Guidelines, waste from electrical and electronic devices should be collected separately. If you need to dispose of this appliance in the future, do NOT throw it away with the rest of your domestic garbage.





# 1. Safety Instruction

## 1-1 Safety instructions

All instructions described should be carefully read and followed.







- These instructions are precautions to prevent the risks of serious injury or death of the user, and any damages to property.

MARKINGS	
 <b>WARNING</b>	WARNING indicates high possibility of serious injury (*1) or death of the user.
 <b>CAUTION</b>	CAUTION indicates high possibility of injury (*2) or property loss (*3).

(\*1) Serious injury – injury which requires hospitalization, lengthy treatment, or blindness, hot and cold skin burn, electric shock, broken bones or poisoning.









(\*2) Injury – injury, skin burn or electric shock which does not require hospitalization or lengthy treatment.



















(\*3) Property loss – extended loss of houses, furniture, domestic animals or pets.



SYMBOLS	
 <b>PROHIBITED!</b>	 <b>PROHIBITED! Indicates prohibited actions.</b> Detailed instructions would be indicated on the inside of the circle or around the symbol in figures or in writing.
 <b>IMPORTANT</b>	 <b>IMPORTANT Indicates mandatory actions.</b> Detailed instructions would be indicated on the inside of the circle or around the symbol in figures or in writing.
 <b>CAUTION</b>	 <b>CAUTION Recommends to take precautions.</b> Detailed instructions would be indicated on the inside of the triangle or around the symbol in figures or in writing.

## \* To use















### **WARNING**









 Instruction	Prior to use, the water purifier must be properly assembled and installed in accordance with this manual. It may damage to the water purifier and cause danger.	
 Away from flammable materials	Do not use the water purifier near a material with high volatility which is easily ignited or exploded. It will cause explosion or fire.	
 Prohibit	Do not use an extension cord with the water purifier. It may cause electric shock or fire due to heat.	
 Electric shock	Do not use damaged power lines, power plug or loose power socket. It may cause electric shock, fault, fire or injuries.	
 Instruction	Make the water purifier on a solid level surface. It may cause the water purifier to fall and tumble down.	

 Prohibit	<p>Do not immerse cord, plug, or any other part of the water purifier in water or other liquids. It may cause electric shock or fire.</p>
 Away from children	<p>Do not operate the water purifier by weak people (including children) which are reduced physical, sensory, mental capabilities, nor inadequate experience and knowledge, unless sufficient instructions have been given by the person who can guarantee the safe use of the water purifier. It may cause electric shock, damage, or malfunction.</p> 
 Away from children	<p>Children should be supervised to ensure that they do not play with the water purifier. It may cause electric shock, damage, or malfunction.</p> 
	<p>Use outlet with rated voltage AC 220-240V, and don't use multiple outlets. It may cause a fire or an electric shock.</p>
 No dis-assembly and repair without permission	<p>Do not damage power line. Do not damage, cut, process power line or bend, pull, twist or bind power line. Besides, do not yank the power line violently, or put weights on the line or clamp the power line. The power line may be damaged and cause fire or electric shock if the power line is damaged, the damaged line must be replaced by the manufacturer or its service agent or personnel having similar qualification, so as to prevent dangers.</p> 
 Insert plug	<p>Insert the power plug securely to the base and let the cord go downward. If the cord goes upward or if the plug is incompletely inserted, it may cause fire due to electric leakage or heat generation.</p> 
 Wipe off dust	<p>Wipe off dust or dirt accumulated on the plug of power line. The accumulated dust or dirt may cause fire, electric shock, or short circuit.</p>
 No modification	<p>Do not disassemble, remodel, modify and repair the water purifier. This may cause fire, electric shock or fault, and cause injuries. If repair is required, please contact with the vendor of the water purifier.</p>
 	<p>Do not place anything on the water purifier. It may cause fire, electric shock or injuries.</p> 
 Care for cleaning	<p>To clean the water purifier, use the soft cloth moisten by the neutral detergent diluted with water. DO not use the insecticide, Thinner, Benzine, chlorine or acid lotion. It may cause crack, electric shock, fire, or deleterious gas.</p>
 No freeze	<p>Do not freeze. It may cause leakage or other malfunctions. Reverse osmosis membrane filters will be damaged below 0°C.</p>
 	<p>Do not fill undrinkable water to the tank of water purifier. This water purifier is exclusively for the tap water with known ingredient. It may damage health or cause trouble.</p> 

	Do not switch on if there is a possibility that the water in the heater is frozen.
	Power connections must be made with reliably grounded devices.







 **CAUTION**

 Prohibit	Do not use outdoors. Keep the water purifier at dry place and away from direct sunlight. It may cause fire or malfunction. Also the body of the water purifier may change color, deform and breeds moss and fungus.	
 No pulling by force	When disconnecting the plug from the socket, do not pull the power line by force. Pull out by grasping the power plug. It may cause electric shock or fault and cause injuries.	
 Application environment	Indoor use only. This appliance is intended to be used in household and similar applications such as staff kitchen areas in shops, offices and other working environments; farm houses and by clients in hotels, motels and other residential type environments; bed and breakfast type environments; catering and similar non-retail applications.	
 Application range	The water purifier usage temp range is between 4°C~38°C. Do not use the water purifier out of usage temp range. The flow rate will be reduced when the environmental temp gets lower. This is the inherent feature of RO membrane. This product is only suitable for safe use in the area below 1500 meters above sea level.	
 Away from fire	Do not place the water purifier close to fire. It may damage to the water purifier and cause fire.	
 Prohibit	Do not put anything on the water purifier, also do not lean, shake and push the water purifier. It may damage to the water purifier and cause injury, leakage, electric shock, fire or others.	
 No water spraying	Do not install the water purifier in where the water jet washer is used. It may cause electric shock or fire due to an insulation deterioration.	
	Stay away from the fire source above 30cm. It will cause fire or machine damage.	
	Do not reset the filter except to replace expired filters or to stop using them for long periods. It may cause adhesion of germs or water leakage.	
	Do not connect hot water pipe of water heater to the water inlet. Reverse osmosis membrane filter will be damaged above 38°C.	
	When water leakage remove the water tank and unplug the power cord as soon as possible. Leakage can cause other damage. Please contact the local service center.	





	Replace the filter regularly. The filter change lamp will flash when the filter need to change. Please see page 10 for 4-2 Filter Change.	
	Do not install close to strong magnetic devices. It may cause fire, damage or circuit failure.	
	The water purifier shall be installed or removed by professional. It's easy to damage the inner parts or cause electric shock.	
	It's normal that there will be slight noise and vibration when the water purifier is producing water.	
	In order to avoid a hazard due to inadvertent resetting of the thermal cut-out, this appliance must not be supplied through an external switching device, such as a timer, or connected to a circuit that is regularly switched on and off by the utility.	





### \* To inspect and maintain

#### WARNING

 No dis-assembly and repair without permission	If the supply cord is damaged, it must be replaced by the manufacturer, its service agent or similarly qualified person in order to avoid a hazard. It may cause fire, electric shock.	
 Prohibit	Do not clean the water purifier with high water pressure equipment. It may cause electric shock or fire due to an insulation deterioration.	
 Disconnect power plug	Make sure the water purifier's power plug disconnects from the power outlet before clearing or inspect the water purifier. It may cause electric shock.	
 Instruction	Disconnect the power plug from power supply immediately and call for service when: - burnt smell from the water purifier - abnormal phenomenon happens. It may cause short circuit, fire or electric shock.	

#### CAUTION

 Certified technician	Service should be performed only by a certified technician. It may damage to the purifier and cause electric shock.	
 Indoor	Do not use the water purifier outdoor. It may cause malfunction, fire or electric shock. And also it may cause the water purifier body color changed, deformation, growth of moss or contamination.	
 Instruction	Do not operate the UV-C emitter when it is removed from the appliance enclosure.	
 Instruction	This appliance contains a UV-C emitter.	

 Prohibit	Unintended use of the appliance or damage to the housing may result in the escape of dangerous UV-C radiation. UV-C radiation may, even in little doses, cause harm to the eyes and skin.
 Prohibit	Appliances that are obviously damaged must not be operated.
 Instruction	The user is not allowed to replace the UV-C emitter individually.
 Prohibit	Disconnect the appliance from the supply before carrying out maintenance.
 Instruction	The appliance is to be supplied through a residual current device (RCD) that rated residual operating current does not exceed 30 mA.

### 1-2 Packing list

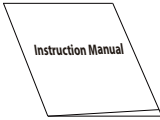
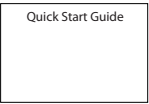
	Instruction Manual	Quick Start Guide
Packing box		

## 2. Product Introduction

### 2-1 Name of parts

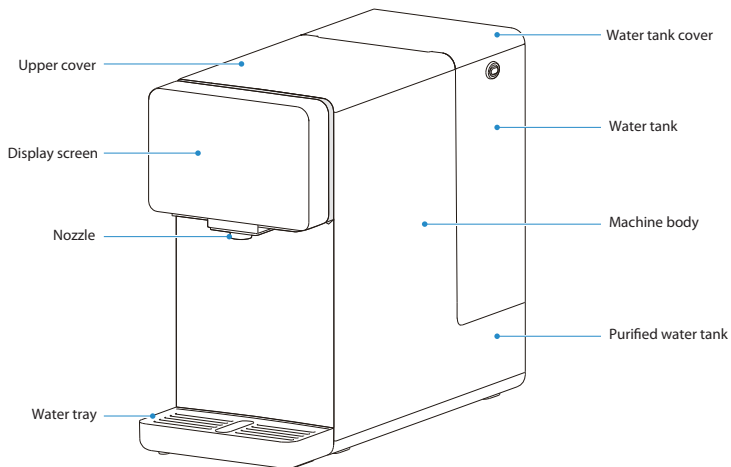

## 2-2 Control panel

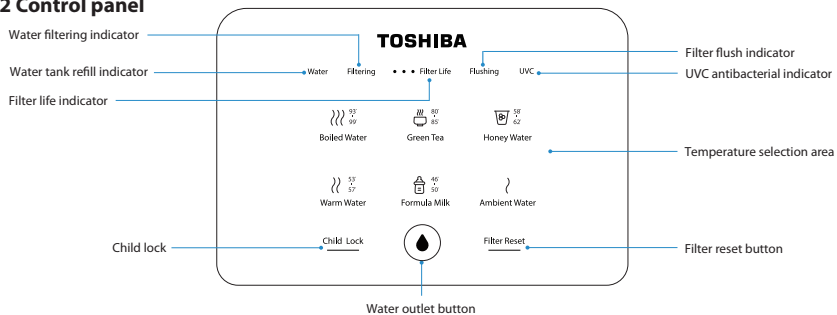

## Button instructions

### 6 water temperature options

- 93°-99° Boiling Water
- 80°-85° Green Tea
- 58°-62° Honey Water
- 53°-57° Warm Water
- 46°-50° Formula Milk
- Ambient Water

### Water tank refill:

When the water tank is taken out or the water level reaches the minimum water level of the water tank, the "Water" icon will flash.

### Water filtering:

When "Filtering" icon flashes, it means that the machine starts to make and filter water into the purified water tank, and the water cannot be dispensed temporarily;

When the clean water tank is at high water level, the "Filtering" icon will turn off.

### Filter flushing:

After connecting to the power supply for the first time or resetting the lifespan of the filter, the machine will automatically flush the filter and the "Flushing" icon will flash simultaneously;

When the filter flushing process is complete, the "Flushing" icon will turn off.

### Standby and activate:

The machine will automatically enter the standby state if there is no operation within 10 minutes, and all the prompt lights on the operation panel will go out;

In standby mode, press any button will make the machine return to working status.

### Child lock:

If you take water at a temperature other than ambient water, the child lock button will light up. You need to click it to unlock, and then press the Water outlet button;

If you take water at ambient water, just press the water outlet button directly;

You can also press and hold for 3 seconds to turn on or off the child lock function.

### Filter replacement:

With the use of the filter, the three small grids for reminding the filter life will turn off one by one.

If all three grids flashes simultaneously, it means that the filter reaches the end of its lifespan and needs to be replaced. At the same time, the filter reset button will light up;

After replacing the filter, press and hold the Filter reset button for 3 seconds to reset the filter life.



## 2-4 Electric schematic diagram

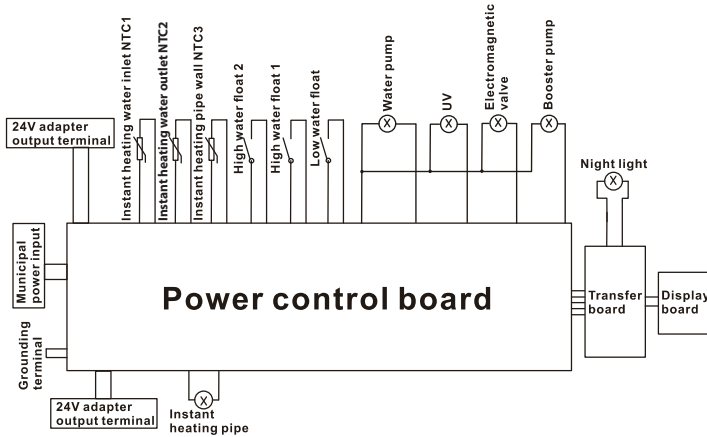

## 2-4 Instructions

### ⚠ Notes:

Do not disassemble the machine yourself. This operation should be performed by professional personnel at authorized service centers or local dealerships.

### Instructions for first use

- Open the package, place the machine on a stable surface and place the water tray and remove the protective cover of the water nozzle.
- Steps to remove the water tank:
  - Remove the water tank cover;
  - Lift the handle of the water tank and pull the water tank outward, and then lift it out after it disconnect with the base.
- Water filling:  
Fill the water tank with tap water to the maximum level.
- Install the water tank:
  - Align the water tank with the base socket and press down;
  - Cover the water tank with the cover, ensuring that the top of the water tank cover is aligned with the top of the machine.
- Rinse filter:
  - Put the water tank back into the machine, and the "Flushing" light will flash. The machine will start to flush the filter automatically for 5 minutes.
  - When it finishes filter flushing, it will beep for 3 times. "Flushing" light will turn off, and the "Water" icon will flash. At this time, it is necessary to pour out all the water in the water tank and refill it to the highest water level.
  - Repeat steps "5.1" and "5.2" for a total of 3 times.

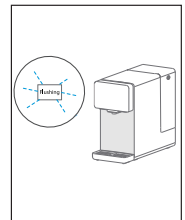
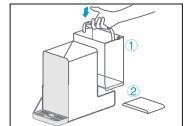
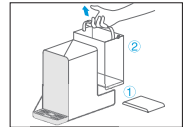
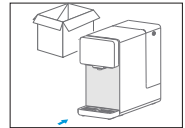

6. Start water making:

The water tank is connected to the fourth water tank and water making begins. It takes about 10-15 minutes for the new machine to make water, please wait patiently.

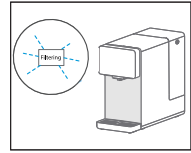

7. After the water making is completed, press the "Ambient Water" button to discharge an appropriate amount of water to clean the internal pipeline and water nozzle, and the machine can be used normally. (optional)

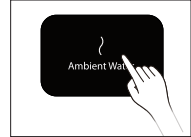

8. When the machine is initially powered on, fill the water tank with water. The machine will start filtering the water until the purified water tank is filled. Once the purified water tank is filled, the machine will enter standby mode.

9. Take water

9.1 Press any icon to light up the screen, indicating that the machine has entered the working state. The screen will remain light for 10 minutes.

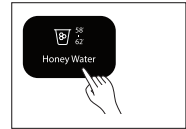

9.2 Ambient water

After the screen is on the temperature automatically defaults to ambient water. Simply press the water outlet button to obtain ambient purified water.

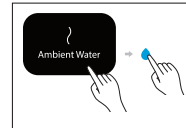

9.3 Other options

When selecting water at temperatures other than ambient water, the child lock button will light up, indicating that you need to press on it to unlock and take the water.

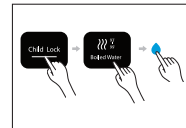

10. Water refill reminder

When the water level reaches the minimum water level, the "Water" icon on the display will flash, please pour out the remaining water from the water tank, and fill the water tank with tap water to the maximum water level, and install the water tank back into the machine.

## 2-5 Daily maintenance

1. Water Tray: Remove the water tray and empty any remaining water in the tray.

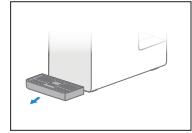

2. Water Tank: It is recommended to add a small amount of descaling agent (such as citric acid) to the water tank once a month. Let it soak for 30 minutes before cleaning. Please do not use organic solvents like gasoline for wiping.

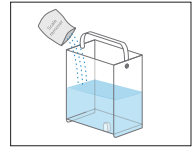

3. If the machine has not been used for more than a week: please empty the water tank first, then press and hold the Ambient Water button for 3 seconds to drain the remaining water from the machine, and finally disconnect the power.

(Note: Press and hold the Ambient Water button for 3 seconds for internal drainage, only ambient water is discharged, and the heating function cannot be activated.)

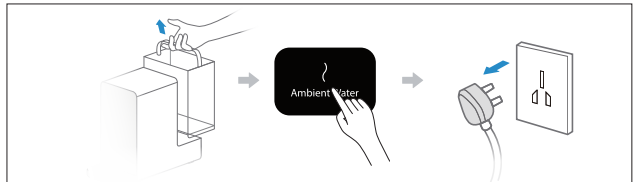

## 3. Troubleshooting

### ⚠ Notes:

The following is the judgment and inspection of common abnormalities. If simple treatment cannot be eliminated, please send it to the maintenance office for consultation. Please do not disassemble and repair yourself to avoid danger or damage to the water purifier.

- The pump may make slight noise when it operates in the purifying and filtering of the water purifier. You can use it normally.
- If there is any problem in using, please solve as the following methods. For the fault that cannot be solved, please contact the local sell service center.

Issues	Troubleshooting
No power supply	<ul style="list-style-type: none"> <li>• Please check if the power is connected.</li> </ul>
Failure to heat normally	<ul style="list-style-type: none"> <li>• Please check whether the supply voltage meets the requirements of 220-240V±15%.</li> </ul>
Failure to heat normally	<ul style="list-style-type: none"> <li>• Please check whether the water tank is installed in place and whether there is water in the raw water tank.</li> </ul>
	<ul style="list-style-type: none"> <li>• Please check that the filter is installed in place and the filter cover is in the correct position.</li> </ul>
	<ul style="list-style-type: none"> <li>• Please check whether the water tank and the water inlet connected to the water tank are blocked by foreign objects.</li> </ul>
	<ul style="list-style-type: none"> <li>• Please check if the filter life is expired.</li> </ul>

Issues	Troubleshooting
The machine does not stop water production for a long time	<ul style="list-style-type: none"> <li>• Please check if the filter life is expired.</li> </ul>
Water leakage	<ul style="list-style-type: none"> <li>• Please check whether the water tank is installed in place.</li> </ul>
	<ul style="list-style-type: none"> <li>• Please check that the filter is installed in place and the filter cover is in the correct position.</li> </ul>
	<ul style="list-style-type: none"> <li>• Replace the filter.</li> </ul>
Odor	<ul style="list-style-type: none"> <li>• To ensure cleanliness, please clean the machine regularly. When it is not in use for a long time, please pour out the water in the water tank, and hold the "Ambient Water" buttons for 3 seconds to drain all the water in the purified water tank.</li> </ul>
The screen does not turn on and the machine cannot be operated	<ul style="list-style-type: none"> <li>• Please unplug the power plug and power on again.</li> </ul>

## 4. Filter Introduction

### 4-1 Filter introduction

Filter name	Quantity	Filter form	Suggested service life	Function
Integrated composite filter FIST(FOF)	1	PAC layer	12 months	Effectively filter mud, sand, rust, suspended solid and other large-grained substance and organic and residual chlorine.
		RO membrane layer		The theoretical filtering precision of RO membrane filter element is up to 0.0001-0.001 micron. RO membrane filter intercept organics (trichloromethane and carbon tetrachloride), heavy metal (arsenic, lead and cadmium etc.) in water.
		Carbon block layer		Effectively filter organics (trichloromethane and carbon tetrachloride), remaining chlorine, odour and peculiar smell etc. in water.

#### Special Prompt:

- The lifespan of filter element is not quality guarantee time, but the ideal lifespan of filter with the raw water in accordance with the national standard of domestic drinking water and based on the normal water using of a common family.
- The maintenance period of filter is expected time, but the real lifespan is depend on area, the quality of water, the quantity of water using and season(it is subjected to the suggestions of local sell on commission and service site). Only change filter timely, you can drink pure water.

### 4-2 Filter Replacement

#### ⚠ Notes:

- The filter can be replaced by yourself or contact with Toshiba service.
- Minor water leakage during the filter replacement process is normal.
- Filter model: FIST (FOF).

1. When all three small grid of the filter life are flashing, please call the after-sales phone number to purchase a new filter.



2. Before replacing the filter element, remove the water tank and place a 2L water container under water nozzle. Press and hold the Ambient Water button for 3 seconds to drain the internal water. After completing the drainage, install the water tank back into the machine.  
(If internal drainage is not carried out beforehand and the filter is replaced, the filter flushing cannot be carried out, and the filter life will be affected)

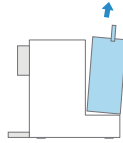

3. The power must be cut off before replacing the filter.

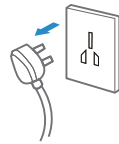

4. As shown below:

① Follow the steps shown below to replace the filter.

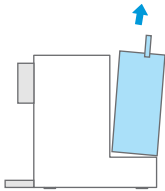

Remove the water tank

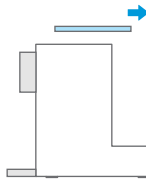

Open the upper cover

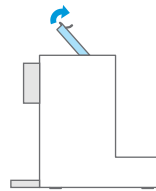

Open the filter cartridge handle

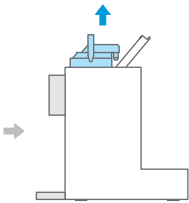

Pull out the filter

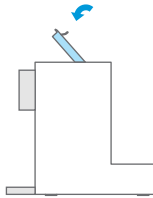

After replacing it with the new filter, press down the pressure lever until there is a "snap" and it is locked.

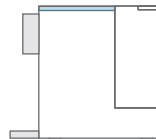

Place the water tank after closing the upper cover

② After the filter is replaced, press and hold the filter reset button for 3 seconds to re-record the life of the filter.

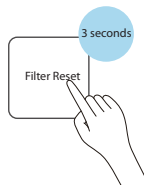

## 5. Technical Parameters

### 5-1 Basic parameter

Model	TWP-TSR76TTH(W)
Rated voltage/ frequency	220-240V~ / 50Hz
Rated hot water capacity	≥90°C, 20L/h
Rated power	2190W
Rated quantity of pure water	2500L
Purified water flow	0.2L/min
Inlet water pressure	0.05-0.1MPa
Work pressure of RO membrane	0.45-0.8MPa
Suitable water resource for using	Municipal water
Applicable ambient temperature	4-38°C
Exterior colors	White