

TOSHIBA

TABLE BLENDER

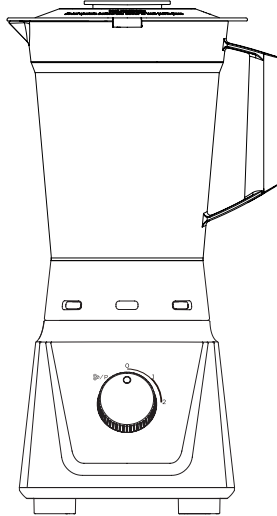

USER MANUAL

BL-60PHNMY

CONTENT

IMPORTANT SAFETY INSTRUCTIONS.....	1
PART NAME.....	3
TECHNICAL DATA OF THE PRODUCT	3
INSTRUCTIONS FOR USE.....	4
RECIPES.....	8
ABNORMALITY ANALYSIS AND HANDLING.....	8
CLEANING AND MAINTENANCE	9
CIRCUIT PRINCIPLE DIAGRAM.....	10

IMPORTANT NOTE: Please read the manual carefully before operating your product. Retain it for future reference.

IMPORTANT SAFETY INSTRUCTIONS

When using electrical appliances, basic safety precautions should always be followed including the following:

1. There is a potential injury from misuse. Please handle it with care.
2. Always disconnect the appliance from the supply if it is left unattended and before assembling, disassembling or cleaning.
3. This appliance shall not be used by children. Keep the appliance and its cord out of children reach.
4. Appliances can be used by persons with reduced physical, sensory or mental capabilities or lack of experience and knowledge if they have been given supervision or instruction concerning use of the appliance in a safe way and if they understand the hazards involved.
5. Children shall not play with the appliance.
6. Be careful when handling the sharp cutting blades, emptying the bowl and during cleaning.
7. Be careful if hot liquid is poured into blender as it can be ejected out of the appliance due to a sudden steaming.
8. Switch off the appliance and disconnect from supply before changing accessories or approaching parts that move in use.
9. This appliance is intended to be used in household and similar applications such as:
 - Staff kitchen areas in shops, offices and other working environments;
 - Farm houses;
 - By clients in hotels, motels and other residential type environments;
 - Bed and breakfast type environments.
10. This appliance conforms to EC Regulation 1935/2004 on materials and articles intended to come into contact with food.
11. Do not exceed the maximum indication on the blender jar, the mill (specific types only) beaker and the chopper bowl (specific types only).

IMPORTANT SAFETY INSTRUCTIONS

12. If food sticks to the wall of the blender jar, switch off the appliance and unplug it. Then use a spatula to remove the food from the wall.
13. Never fill the blender jar with ingredients hotter than 80°C.
14. The appliance can only be switched on if the blender jar or the beaker is assembled on the motor unit correctly.
15. Do not let the appliance run for more than 2 minutes or 30 seconds at a time. Let the appliance cool down to room temperature before you continue processing.
16. If the supply cord is damaged, it must be replaced by the manufacturer, its service agent or similarly qualified persons in order to avoid a hazard.

SAVE THESE INSTRUCTION.

THIS UNIT IS INTENDED FOR HOUSEHOLD USE ONLY.

Caution:

Ensure that the blender is switched off before removing

Caution:

The failure to follow any of the important safeguards and the important instructions for safe use is a misuse of your table blender that can void your warranty and create the risk of serious injury.

PART NAME

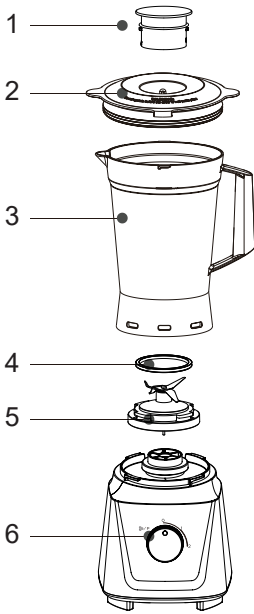

No.	Description
1	Measuring cup
2	Blender jar cover
3	Blender jar (1.5L)
4	Blender jar seal
5	Blade system
6	Speed control dial
7	200ml jar
8	Jar seal
9	Grinder blade system
10	Spatula

ACCESSORIES

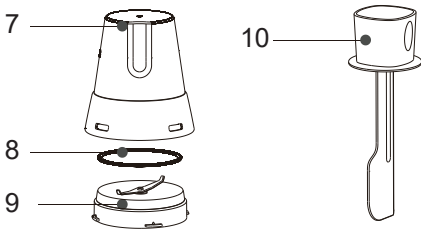

TECHNICAL DATA OF THE PRODUCT

Product name	Model No.	Rated voltage	Rated frequency	Rated power	Effective capacity
TABLE BLENDER (Eccentric blender jar)	BL-60PHNMY	220-240V~	50-60Hz	600W	1.5L

INSTRUCTIONS FOR USE

Table blender

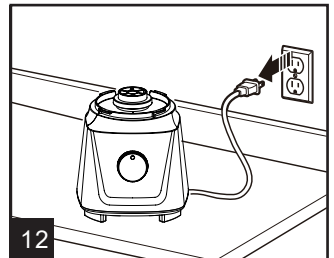
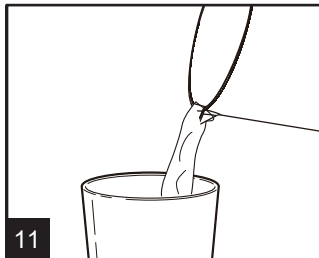
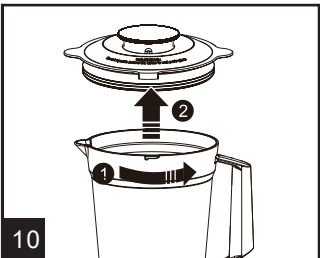
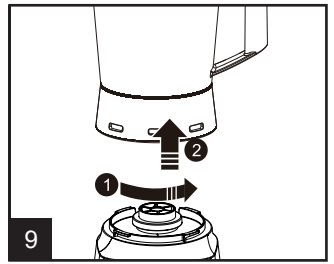
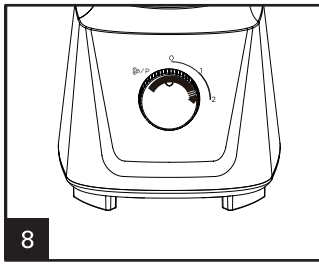
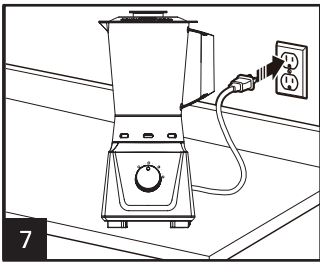
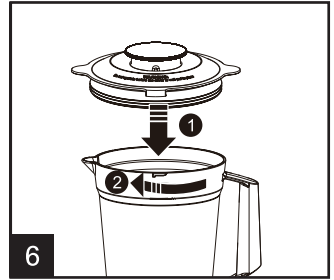
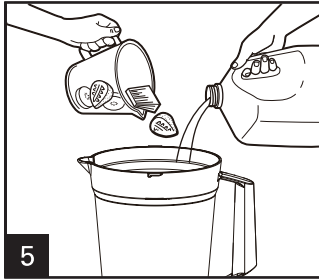
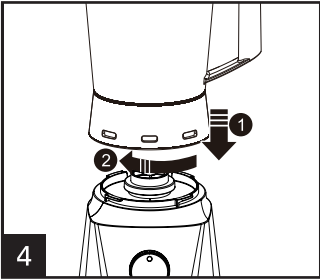
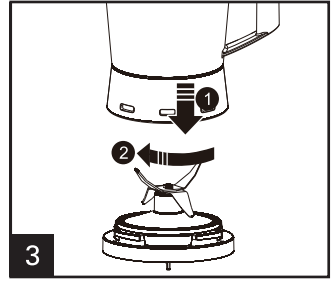
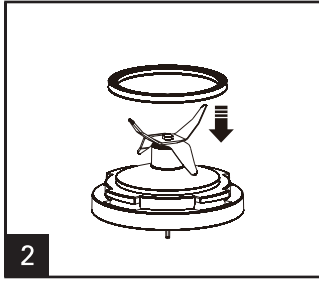
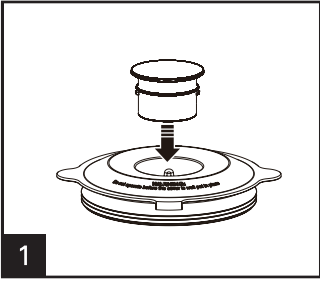

INSTRUCTIONS FOR USE

Grinder

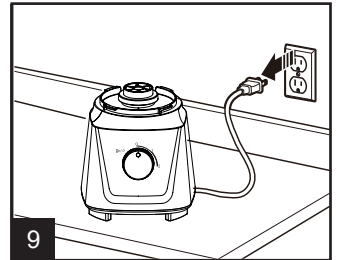
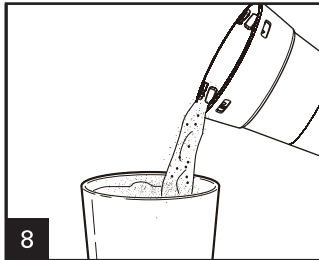
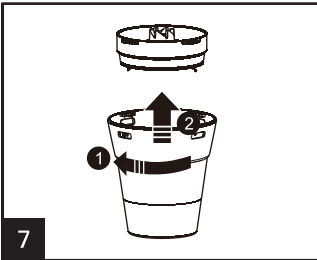
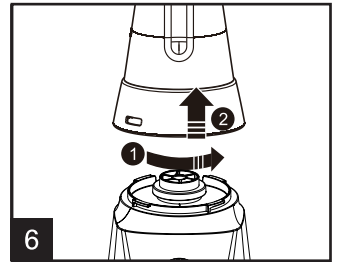
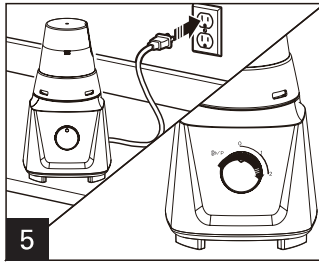
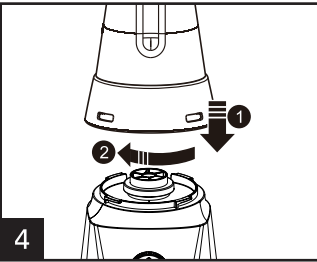
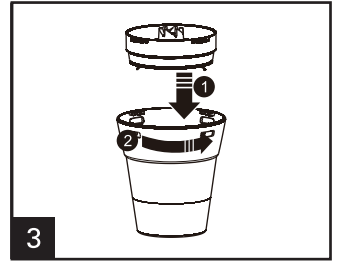
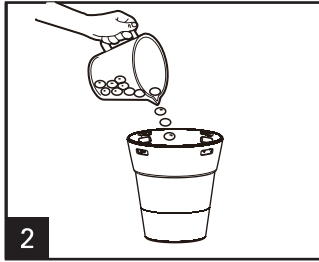
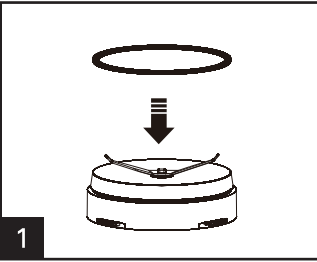

Spatula

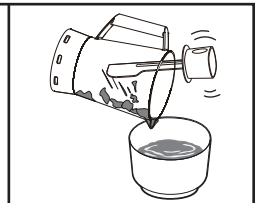
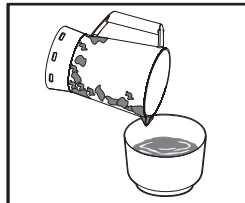
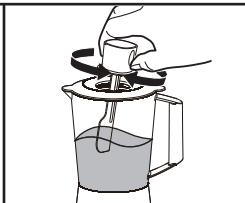
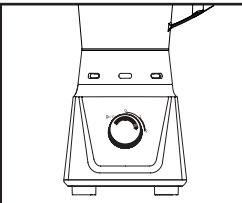

- When the blender is switched on, use the spatula to enhance the smoothness and consistency of result.
- When the blender is switched off, use the spatula to remove the sticky ingredients in the jar.

INSTRUCTIONS FOR USE

Before first use

- Before using your blender for the first time, remove any packaging material and promotional labels.
- Be careful when handling the blades as they are extremely sharp.
- Wash the jug, lids, blade assembly and attachments in warm soapy water with a soft cloth. Rinse and dry thoroughly. All parts (except motor base) may be washed in the dishwasher, on the top shelf.

Functions (Speed)

MOTOR BASE SPEED CONTROL

Many recipes process best with a combination of speeds with occasional use of pulse.

PULSE

Momentary burst of high power.

CHOP (speed 1)

Low speed to combine more delicate foods with a folding motion, and is good for combining wet and dry ingredients.

LIQUIFY (speed 2)

High speed is ideal for breaking down ingredients to make ice based drinks and other finely blended mixtures.

Warning:

Hot liquids can erupt during blending. Do not blend hot liquids.

BLENDING JUG

- Run the blender only for the appropriate amount of time required.
- Do not over blend ingredients.
- Use the PULSE setting when food is too thick or coarse to circulate within the blender jug.
- Do not exceed the maximum mark.
- If any moisture or liquid appears on top of the motor base during blending, turn the blender off and unplug at the wall. Remove the blender jug, and wipe motor base

INSTRUCTIONS FOR USE

immediately with a dry cloth or paper towel.

- The maximum amount of ice cubes that the blender can process is 8 cubes from a standard ice tray.
- Use the PULSE function for foods that only require short bursts of power, such as chopping nuts and crushing ice.
- When blending drinks with ice cubes or frozen fruit, use PULSE in short bursts.
- Thicker mixtures puree more efficiently if the jar is too full.
- Do not use metal utensils, as they may damage the blades or blender jar.
- Do not blend a heavy mixture for more than 10 seconds. For normal blending tasks, do not blend longer than 1 minutes at a time. If you need to blend longer, turn off the blender and stir ingredients before starting again.
- This rest will help protect the motor from wear and tear.
- The blender will not knead dough, or mash potatoes.
- When blending warm ingredients, do not put more than 2 blending bottles at a time in.
- Do not blend hot or boiling ingredients. Allow food to cool down to a warm state before placing in the blender. This is to safeguard against sudden bursts of steam that could cause the lid to dislodge.
- If blending warm ingredients, place a tea towel over the lid and hold down firmly.

Overload protection system

- Machine running time cannot be more than 3 minutes. After the shutdown, it is necessary to let it fully heat, cooling to room temperature.
- The MAX line is usually a good indicator to prevent overly heavy loading, however some especially dense combinations of ingredients may still strain the motor. If the motor seems to be straining or running slowly, only operate for 10 seconds at a time, or reduce the amount of ingredients used. Adding more liquid can also help to loosen dense mixtures.

Note:

- Do not process hot foods or liquids in blender.
- Do not store food or liquids in the blender jar.
- Avoid bumping or dropping the blender.

RECIPES

Food	Preparation	Quantity	Functions (Speed)	Time
Smoothie	Milk, fruit, yoghurt, ice cream	Max 800ml	Chop (speed 1); Liquify (speed 2)	60 secs
Ice or frozen fruit	Frozen no larger than standard ice tray	Max 8 pieces	Pulse; Liquify (speed 2)	60 secs
Blended soups	Cool to room temp	800ml	Chop (speed 1)	50–60 secs
Grinder	Coffee bean	50g	Speed 2	30 secs
Chopper	Onions	60g	Speed 2	30 secs

Note:

- This blending chart should be used as a guide only.

ABNORMALITY ANALYSIS AND HANDLING

Abnormality Handling

1. In case of abnormalities such as abnormal noises, smell, smoke, etc., you should immediately cut off power and stop use.
2. If the product cannot work, please check if the power supply is connected, if the switch is put to the ON position and if fittings are installed in place.
3. If the product still cannot work after checks mentioned above, please consult the designated repair centre for maintenance.

Motor doesn't start or blade doesn't rotate	• Check that the power plug is properly inserted into the power outlet.
Food is lumpy or unevenly chopped	<ul style="list-style-type: none"> • This can happen when too much food is being blended at one time. Try a smaller amount, and work in batches if necessary. • The ingredients may be too large. Try cutting into smaller pieces. For best results, ingredients should be in pieces no larger than 2cm.
Food is chopped too fine or is watery	• Try blending for shorter period of time. Use PULSE for better control. Food sticks
Food sticks to blade and jug	• The mixture may be too thick. Try adding more liquid, and using a slower speed for blending.
Blender stopped suddenly while in use	• We recommend blending in smaller batches, or cutting ingredients into smaller batches.

CLEANING AND MAINTENANCE

Cleaning

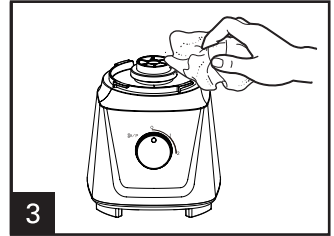
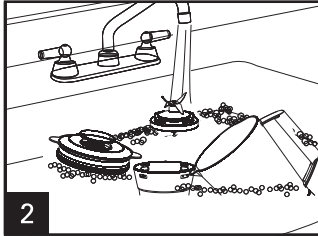
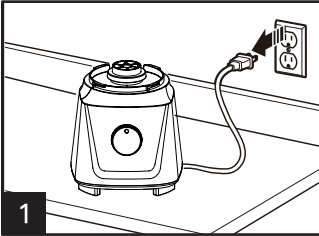

⚠ Warning:

Blades in jar are very sharp. Use caution when cleaning.

Unplug the power cord from the power outlet after use for safety reasons.

Jar, blades and lids

Avoid allowing food residue to dry on. Follow these steps as soon as possible after use:

- Rinse most of the residue off the jar, blades and lids.
- Hand wash in warm, soapy water using a mild liquid detergent and non-abrasive sponge.

Motor base

To clean the motor base, wipe with a soft, damp cloth then dry thoroughly. Wipe any excess food particles from the power cord.

Cleaning agents

Do not use abrasive scouring pads or cleaners on either the motor base or any part of the blender, as they may scratch the surface. Use only warm soapy water with a soft cloth.

Dishwasher

The jar, lids and blade assembly may be washed in the dishwasher on the top shelf only.

Stubborn food stains and odours

Strong smelling foods such as cumin and coriander, and some vegetables such as

CLEANING AND MAINTENANCE

carrots may leave an odour or stain.

To remove, pour warm soapy water and fill to the MAX mark. Set aside to soak for 5 minutes. Then wash with a mild detergent and warm water, rinse well and dry thoroughly. Store blending bottle and jar with lids off.

Maintaining

Store your blender upright with the blender jar assembled on the motor base, or beside it. Do not place anything on top. To allow air to circulate, keep the lid off.

CIRCUIT PRINCIPLE DIAGRAM

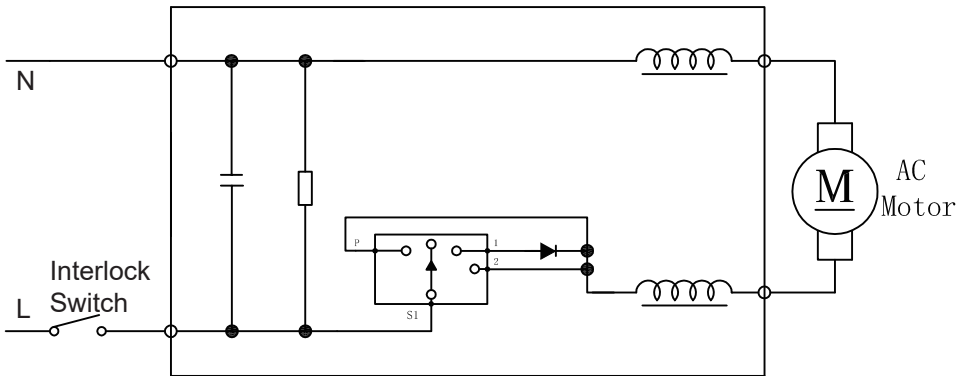

Environmental protection



The appliance must not be disposed of with regular household waste. At the end of its service life, the appliance must be properly delivered to a collection point for the recycling of electrical and electronic equipment. By Collection and recycling of old appliances, you are making an important contribution to the conservation of our natural resources and provide for environmentally sound and healthy disposal.

