



使用說明書

落地扇

F-DSB800XHK(W)

TOSHIBA

目錄

安全注意事項	02
產品簡介	05
產品安裝	06
使用說明	07
產品參數	10
清潔保養	10
故障排除	10

非常感謝您購買東芝電風扇。

- 為了正確、安全地使用本風扇，請在使用前仔細閱讀本用戶手冊，並充分理解其內容。
- 請妥善保管本用戶手冊，以備於將來參考之用。





安全注意事項

- 為了保證使用安全，避免對他人造成傷害和財產損失，請您務必遵守以下安全注意事項。
- 不遵守全警告錯誤使用時可能會導致事故發生。
- 為避免因操作失誤而導致危險，不建議兒童及殘疾人士使用，除非有監護人的監督，否則可以引起觸電、損壞或故障
- 僅限家庭使用。











⚠ 小心

請仔細閱讀“安全操作規則”。









標示符號的說明

 警告	表示可能會導致死亡或重傷的安全事項。
 注意	表示可能會導致輕傷或財產損害的安全事項。
 禁止	表示禁止和不可以做的事項 具體的禁止內容標示在圖示符號中或在其附近用圖畫或文字說明。
 強制	表示強制的，務必遵守的事項 具體的強制內容標示在圖示符號中或在其附近用圖畫或文字說明。
 溫馨提示	表示可能影響使用體驗的其他事項。

安全注意事項

 警告	產品未完成安裝前,請勿接通電源。
 警告	拆下防護外殼前必須確保產品與電源斷開。
 警告	請勿用溼手插拔電源插頭,避免觸電的危險。
 警告	使用前,請先檢查所用電壓是否與產品標識的電壓相同。
 警告	避免在酸鹼油、殺蟲水、窗簾等物品附近使用。
 警告	只能使用配套的適配器工作,不得使用其他適配器,以免引起危險。
 警告	人離開機器時或機器在不使用狀態下,要關掉電源及拔掉電源插頭,以免電路出現故障發生意外。
 警告	使用前需要先檢查電源線及插頭是否破損。如果電源軟線損壞,爲了避免危險,必須由製造商、其維修部或類似部門的專業人員更換。
 禁止	移動產品時,請切斷電源。
 禁止	產品運轉時,切勿將手指、尖銳物等伸入網罩。
 禁止	禁止在有易落下懸掛物、易受衝擊或擺放不穩定的地方使用。使用產品時應放置平穩,請不要翻倒或傾斜。

安全注意事項

 强制	若產品出現故障，請立即關機並拔下電源線插頭送附近特約維修點請專業人員維修。非專職人員或者未授權修理人員，不得自行修理或改造本機。
 注意	小孩、喪失生活自理能力的老人或病人請在成人監護下使用產品，以防發生意外。
 提示	嬰兒、老人不宜長時間直接吹強風。
 提示	避免在陽光直射、長時間高溼度環境使用。
 提示	清潔保養後，一定要等到充分乾燥才能通電使用或收藏。
 提示	長期不用時請將電源線插頭拔下，建議最好用原包裝包好，收藏於乾燥的地方。
 提示	考慮到用戶安全使用風扇產品和節能原因，若機器連續工作超過24小時，且過程中無操作，機器將自動關機。注:如果用戶使用產品定時關機功能，則優先執行定時關機時間操作。
 提示	風扇運行過程中如果用手移動的話，會導致關機復位位置偏位，故不可用手操作。

產品簡介

部件名稱

注意：

說明書圖片僅供參考，具體以包裝箱內實物為準。

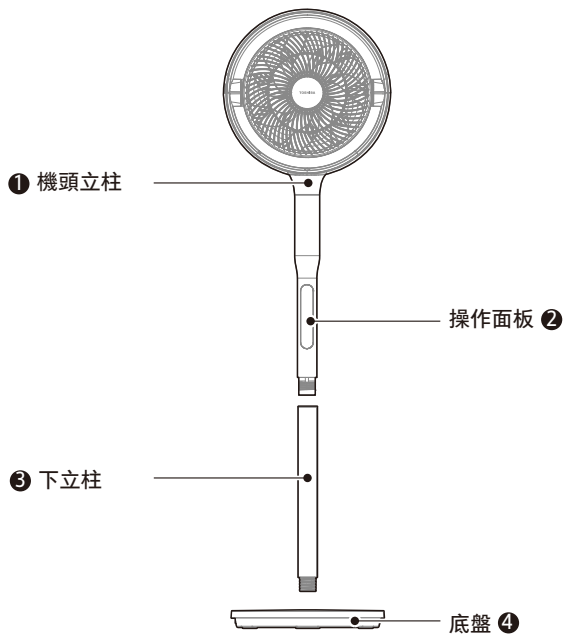

配件清單



遙控器 x1



電池 x2



說明書 x1



適配器 x1

產品安裝

底盤安裝

將立柱和底座介面對準，順時針旋轉擰緊固定

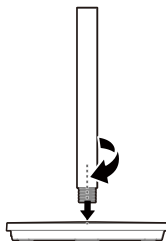

立柱安裝

先將①機頭立柱與②下立柱的孔位對準，然後順時針旋轉進行固定。

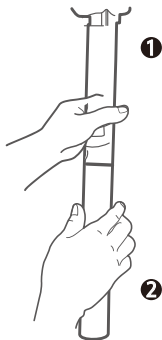



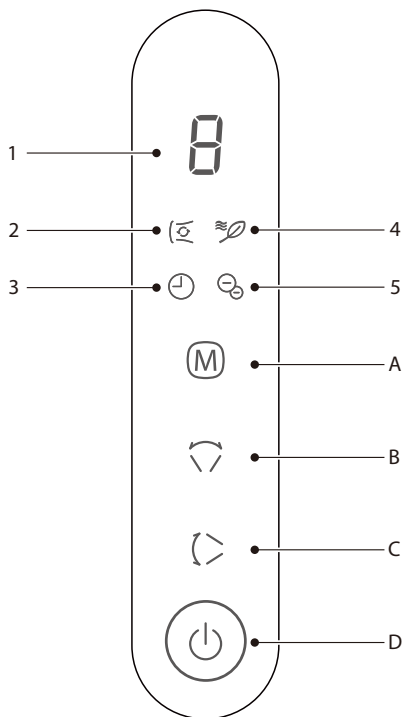



使用說明



No	指示燈	描述
1		• 風速檔位/定時時間顯示區。
2		• 循環風顯示燈 適合大面積使用場景, 如客廳。促進室內空氣循環, 搭配空調, 快速降溫, 讓溫度更均勻。
3		• 定時設置顯示燈
4		• 自然風顯示燈 適合臥室睡眠, 客廳娛樂, 書房辦公等納涼場景。
5		• 負離子顯示燈 適合所有場景使用, 有清新空氣的作用。

使用說明

No	按鈕	描述	功能
A		模式鍵	<ul style="list-style-type: none"> 短按此鍵風速檔位循環切換(循環風1-9檔; 自然風1-6檔); 長按此鍵3秒分類循環切換模式(自然風-循環風...依次循環)。
B		左右搖擺鍵 /負離子鍵	<ul style="list-style-type: none"> 單擊此鍵, 開啓或關閉左右搖擺功能, 左右搖擺角度 60° 長按此鍵3秒可關閉/開啓負離子, “”指示燈亮。
C		上下搖擺鍵 /定時設置	<ul style="list-style-type: none"> 單擊此鍵, 開啓或關閉上下搖擺功能, 上下搖擺角度 $\pm 20^\circ$, 上下手動搖擺角度 $\pm 90^\circ$。 長按此鍵3秒進入定時設置, “”指示燈亮。此時短按此鍵可循環切換定時模式。時間為1-9小時, 以1小時為間隔。
D		開/關機鍵	<ul style="list-style-type: none"> 單擊此鍵, 開啓或關閉機器電源。 (注: 開機默認開啓負離子功能)

使用說明

遙控器按鍵說明

注意：

- 遙控器在產品正面5米內，左右角度在30度範圍內正常使用。
- 遙控器電池中含有許多重金屬和酸鹼等物質，威脅人類健康；廢舊電池應分類回收。
- 請使用“AAA”型錳電池或鹼性電池。請勿使用充電電池。
- 請勿將遙控器電池放入火中，否則電池可能會爆炸或泄漏。另不要將新舊電池混合使用。不要混合鹼性、標準(碳鋅)或可充電(鎳鎘)電池。

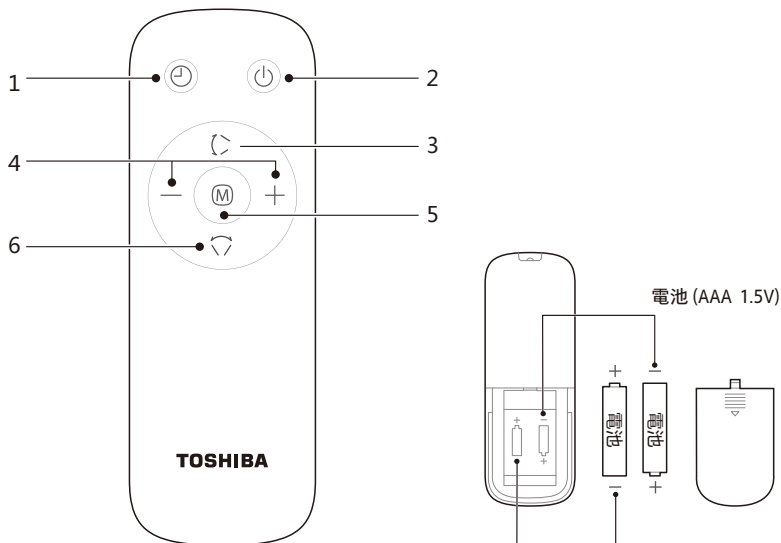

No	按鈕	描述	功能
1		定時關機 /預約開機	<ul style="list-style-type: none">• 開機狀態下設定定時關機，關機狀態下設定預約開機；• 單擊按鍵後，可通過按定時鍵或“+、-”鍵設置定時時間。
2		開/關機	<ul style="list-style-type: none">• 開/關機鍵。
3		上下搖擺	<ul style="list-style-type: none">• 開啓或停止上下搖擺送風。
4	“+、-”	設定風速檔位 或定時設置	<ul style="list-style-type: none">• 設定風速檔位或定時設置。
5		模式鍵	<ul style="list-style-type: none">• 設定風類模式。
6		左右搖擺	<ul style="list-style-type: none">• 開啓或停止左右搖擺送風。

產品參數

型號	F-DSB800XHK(W)
工作電壓	24V ---
額定功率	25W
待機功率	0.8W
噪音	≤63dB(A)

電源適配器 注:請使用本產品原裝適配器, 型號 GM42-240150-D

輸入	100-240V~ 50/60Hz 1.5A
輸出	24V --- 1.5A

清潔保養

注意事項

- 清潔本產品前, 必須關閉電源並拔下插頭。
- 清潔後, 必須待機器充分乾燥才通電或收藏。
- 長期不使用時請將電源線插頭拔下, 建議用原有包裝放好, 收藏於乾燥地方。
- 禁止用水直接沖洗機身, 可用含少許中性洗滌劑的軟布輕擦機器表面, 然後抹乾。請勿使用任何有研磨性清潔劑或溶劑如汽油。
- 禁止拆開機器進行改裝, 建議定期對機器進行檢查和清潔, 以延長其使用壽命。

故障排除

如果風扇在使用過程中出現異常情況, 請在報修前檢查以下幾點。

問題	檢查以下內容
扇葉不旋轉。	<ul style="list-style-type: none">• 風扇扇葉是否安裝正確?• 電源插頭是否插入插座?• 是否有扇葉接觸防護罩?
扇葉旋轉但發出奇怪的聲音。	<ul style="list-style-type: none">• 螺旋殼蓋是否正確地將扇葉固定到位?• 前後網罩部分是否安裝正確?• 是否有扇葉接觸網罩?
	<ul style="list-style-type: none">• 扇葉和網罩是否乾淨?

#DetailsMatter

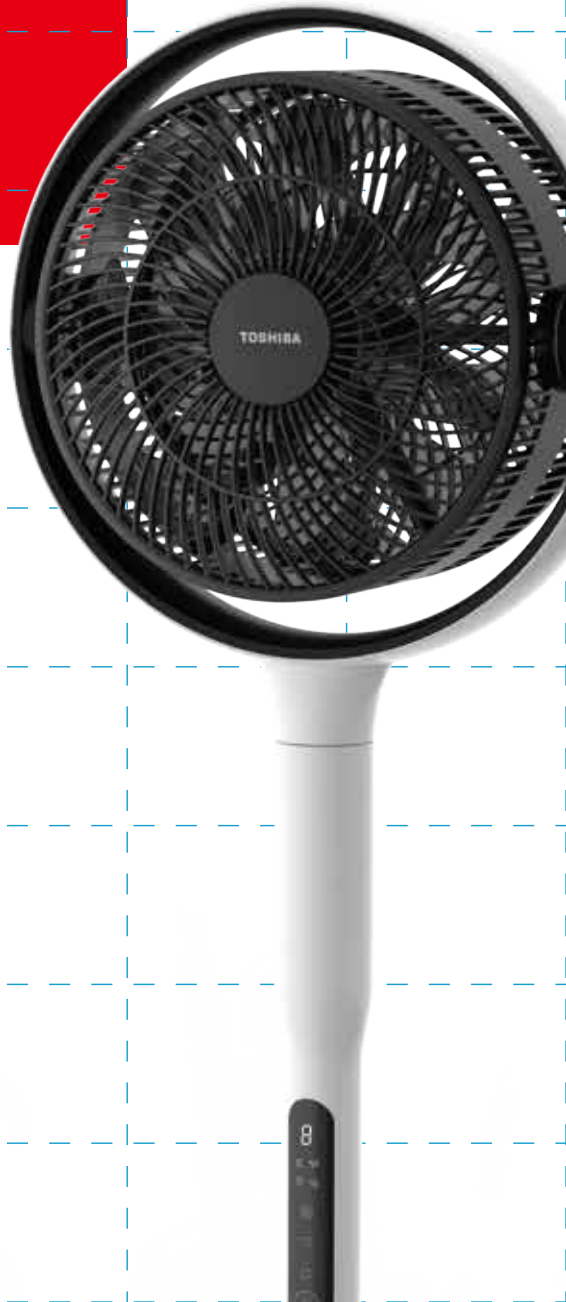

USER MANUAL

STAND FAN
E-DSB800XHK(W)

TOSHIBA

CONTENTS

SAFETY INSTRUCTIONS	02
PRODUCT INTRODUCTION.....	06
PRODUCT INSTALLATION	07
OPERATING INSTRUCTIONS.....	08
SPECIFICATIONS	11
CLEANING AND MAINTENANCE	11
TROUBLESHOOTING	11

Thank you very much for purchasing Toshiba electric fan.

- In order to use this fan correctly and safely, please read this manual carefully and fully understand its contents before using it.
- Keep this owner’s manual in a handy place for future reference.

SAFETY INSTRUCTIONS





Safety precautions

- To ensure the safety of use and avoid injury and property damage ,please always following below safety precautions.
- When use the product incorrectly and failure to comply with warnings can result in accidents.
- In order to avoid the danger caused by improper operation, it is not recommended for children and disabled persons use this product,, unless there is a guardian's supervision, and it can cause electric shock, damage or failure.
- Household use only.

CAUTION

Read Rules for Safe Operation and Instructions Carefully.

A DESCRIPTION OF THE MARKING SYMBOL











 Warning	The signal word indicates a hazard with a medium level of risk which, if not avoided, may result in death or serious injury.
 Caution	The signal word indicates a hazard with a low degree of risk which, if not avoided, may result in minor or moderate injury.
 Prohibit	The signal word indicates prohibited or cannot do things. The specific prohibited content is indicated in or near the pictorial symbol in a picture or text.
 Mandatory	The signal word indicates a mandatory and must-follow things. The specific mandatory content is indicated in or near the pictorial symbol with a picture or text description.

SAFETY INSTRUCTIONS









Attention



The signal word indicates other matters that may affect the user experience

 Warning	Do not connect the power supply until the product is installed.
 Warning	Make sure the product is disconnected from the power supply before removing the protective casing.
 Warning	Do not plug or unplug the power plug with wet hands to avoid the risk of electric shock.
 Warning	Before use, please check whether the voltage used is the same as the voltage marked on the product.
 Warning	Avoid using it near acid-base oils, insecticides, curtains and other items.
 Warning	Only the matching adapter can be used. Do not use other adapters so as to avoid danger.
 Warning	When you leave the machine or when the machine is not in use, turn off the power and unplug the power plug to avoid circuit failure and accidents.
 Warning	Before use, check whether the power cord and plug are damaged. If the power cord is damaged, it must be replaced by the manufacturer, its maintenance department or a specialist from a similar department in order to avoid danger.
 Prohibit	Cut off the power supply before moving the product.
 Prohibit	When the product is running, do not put your fingers or sharp objects into the grille.

SAFETY INSTRUCTIONS

 Prohibit	It is prohibited to use it in places where there are hanging objects that are easy to fall, where it is susceptible to impacts, or where the placement is unstable. The product should be placed stably when using it, please do not tip over or tilt.
 Mandatory	In the event of an exception or malfunction. Please shut down immediately and unplug the power cord and send it to the nearby maintenance station for professional maintenance.
 Caution	Non-professionals and Unauthorized repairman please do not disassemble, repair or modify the product.
 Attention	Children, the elderly or sick people who lose the ability to take care of themselves should use the product under adult supervision to avoid accident.
 Attention	Infants and the elderly should not blow strong winds directly for a long time.
 Attention	After cleaning or maintenance, a please be sure the product is fully dry before use or collection.
 Attention	When the product is not used, please unplug the power plug from the power socket. And it is recommended to wrap the product in its original packaging and store it in a dry place.

SAFETY INSTRUCTIONS

 Attention	<p>In consideration of safety and energy-saving problems, if the machine continuously works for more than 24 hours, and no operation is performed, the machine will shut down automatically. Remark: If the user uses the timer function of the product, the timer operation is preferred.</p>
 Attention	<p>If you move the fan by hand during the running process, the shutdown reset position will be out of position. Therefore, please do not move the fan by hand.</p>

PRODUCT INTRODUCTION

PART NAME

Note:

The pictures in the manual are for reference only. The actual product in the packaging box shall prevail.

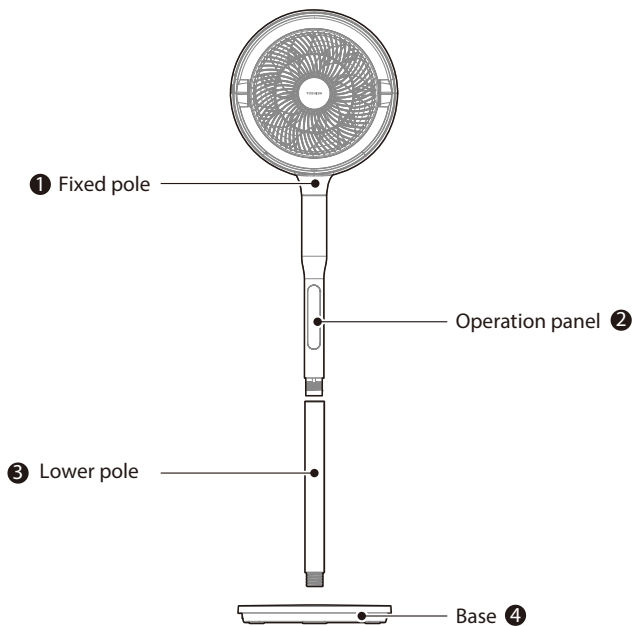

LIST OF PARTS



Remote control x1



Battery x2



User Manual x1



Adapter x1

PRODUCT INSTALLATION

BASE INSTALLATION

Align the post and the base interface, and rotate clockwise to tighten it.

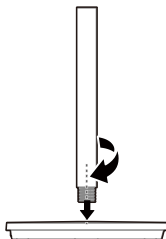





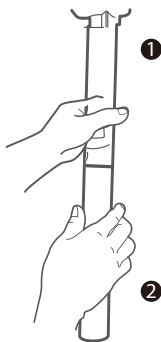

POLE INSTALLATION

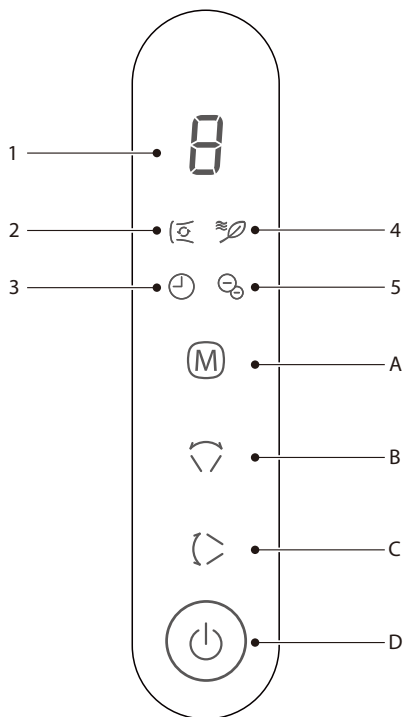
First, align the hole of the ① fixed pole with the hole of the ② lower pole, and then rotate clockwise to fix them.







OPERATING INSTRUCTIONS



No	Indicator	Function
1		• Fan speed level/schedule time display area.
2		• Circulating wind indicator It is suitable for large area cooling in the living room. It stirs indoor air circulation and uses with air conditioner to quickly cool down and make the temperature more uniform.
3		• Timer indicator
4		• Natural wind indicator It is suitable for sleeping in the bedroom, entertaining in the living room, working in the study and other cooling scenes.
5		• Negative ion indicator It is suitable for use in all scenes and has the function of fresh air.

OPERATING INSTRUCTIONS

No	Button	Description	Function
A		Mode button	<ul style="list-style-type: none"> Press this button to switch the wind speed cyclically (circulating wind cycles among level 1-9; natural wind cycles among level 1-6); Press and hold this button 3 seconds to cycle wind mode (natural - circulating... in sequence).
B		Horizontal oscillator/negative ion button	<ul style="list-style-type: none"> Press this button to turn on or off the horizontal oscillator function, and the horizontal oscillating angle is 60°. Press and hold the button to turn off/on negative ions, and the "⊖" indicator will light up.
C		Vertical oscillator/timer setting button	<ul style="list-style-type: none"> Press this button to turn on or off the vertical oscillator function, and the automatic vertical oscillating angle is ±20°, and the manual oscillating angle is ±90°. Press and hold the vertical oscillator button 3 seconds to enter the timer setting, the "⌚" indicator will light up. At this moment, you can press this button to switch the schedule time cyclically. Scheduled time is in the range of 1 to 9 hours in 1 hour increment.
D		On/off button	<ul style="list-style-type: none"> Press this button to switch on/ off the fan. (Note: When powered on, the negative ion function is turned on by default)

OPERATING INSTRUCTIONS

DESCRIPTION OF REMOTE CONTROL BUTTONS

Note:

- The remote control can be used normally within 5m from the front of the product and the deviation angle is within 30°.
- Remote control batteries contain many heavy metals, acids and alkali and other substances, which threaten human health; used batteries should be classified and recycled.
- Please uses AAA manganese batteries or alkaline batteries. Do not use rechargeable batteries.
- Do not put the remote control battery into fire, or the battery may explode or leak. Do not mix old and new batteries. Do not mix alkaline, standard (carbon-zinc) or rechargeable (nickel-cadmium) batteries.

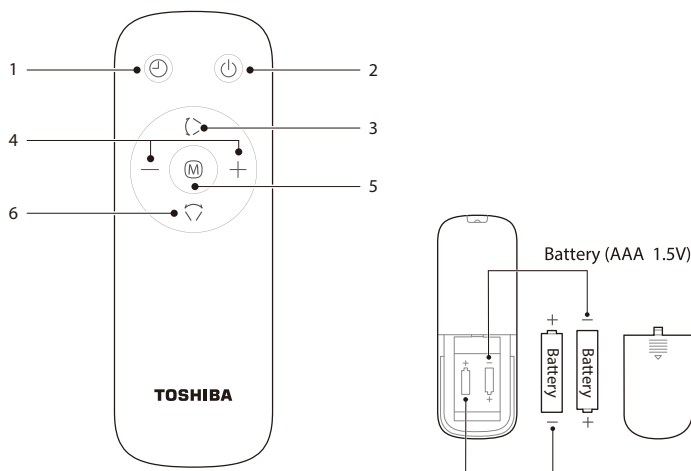

No	Button	Description	Function
1		Scheduled power off/on	<ul style="list-style-type: none"> • Set the scheduled power-off in the power-on state, and set the scheduled power-on in the standby state; • After clicking the button, you can set the schedule time by pressing the timer button or the “+,” “-” buttons.
2		On/off	<ul style="list-style-type: none"> • On/off button.
3		Vertical oscillator	<ul style="list-style-type: none"> • Start or stop vertical oscillator.
4	“+、-”	Set fan speed or schedule time	<ul style="list-style-type: none"> • Set the fan speed or schedule time.
5		Mode button	<ul style="list-style-type: none"> • Set the fan mode.
6		Horizontal oscillator	<ul style="list-style-type: none"> • Start or stop horizontal oscillator.

SPECIFICATIONS

Model	F-DSB800XHK(W)
Operating voltage	24V ---
Rated power	25W
Standby power	0.8W
Noise	≤63dB(A)

POWER ADAPTER

(Attention : Please use the original adapter, model number GM42-240150-D)

Input	100-240V~ 50/60Hz 1.5A
Output	24V --- 1.5A

CLEANING AND MAINTENANCE

Precautions

- Before cleaning this product, be sure to turn off the power switch and unplug it.
- After cleaning, must wait until it is fully dry before powering on for use or storage.
- Please unplug the power cord when not in use for a long time. It is recommended to wrap it in the original packaging and store it in a dry place.
- Do not rinse the machine body directly with water. Use a soft cloth containing a little neutral detergent to gently wipe the surface of the machine, and then wipe it dry. Do not use solvents such as gasoline.
- It is prohibited to disassemble the machine for modification. It is recommended to check and clean the machine regularly to extend its service life.

TROUBLESHOOTING

If the fan appears abnormal during use, please check the following points before repair.

Problem	Check the following
The fan blades do not rotate.	<ul style="list-style-type: none">• Are the fan blades installed correctly?• Is the power plug inserted into the socket correctly?• Is there a fan blade contact protective cover?
The fan blades rotate but make a strange sound.	<ul style="list-style-type: none">• Does the spiral hub cap secure the fan blades in place?• Are the front and rear guards installed correctly?• Is there a fan blade contact protective cover?• Are the fan blades and protective cover clean?

#DetailsMatter